

SWITCHING POWER TRANSFORMERS

Features

- Incorporate ferrite core.
- Adaptable to high frequencies like 20kHz~1MHz.
- Adaptable to various insulated switching system ,such as fly back, quasi-resonant,RCC, forward, push pull, LLC, half bridge, phase shift full bridge etc.
- Usable as inductor for non-insulated DC/DC converter ,such as a PFC choke coil and a secondary smoothing inductor.
- Available to customized design based on safety standard and reliability you need.
- Possible to attain miniaturization by using triple insulation wire and special tape. with a comparative tracking index of $\geq 600V$.

フェライトコアを使用し、20kHz~1MHz程度の高周波に対応した形状です。
 フライバック、擬似共振(RCC)、フォワード、プッシュプル、LLC、ハーフブリッジ、フェーズシフトフルブリッジ等、絶縁型の各種スイッチング方式に対応可能です。それだけでなく、効率改善用PFCチョークコイルや、2次側平滑用チョークコイル、非絶縁型のDC/DCコンバーター用インダクタにも最適設計が可能です。
 これらのトランスやコイルの設計は、容量だけではなく、安全規格や信頼性により、大きさやタイプが変わってきます。
 弊社におきましては、電気的条件を教えて頂くことにより、最適な形状を選定し、設計致します。
 三層絶縁銅線やトラッキング指数の高い材料「ルーフ I (CTI $\geq 600V$)」のテープ等を用いることにより、小型化を提案いたします。

EE.EI-AL

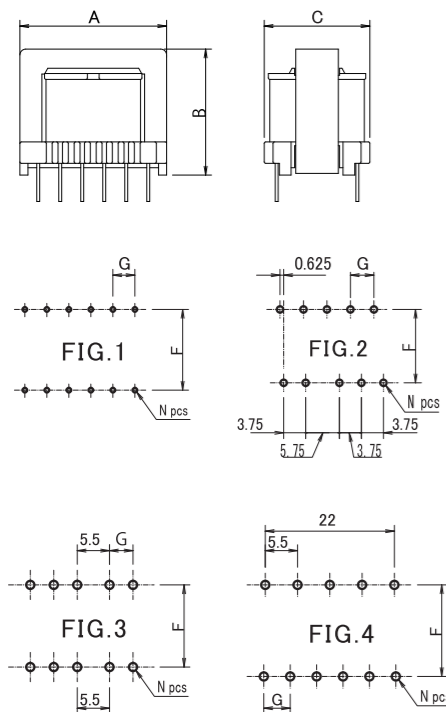
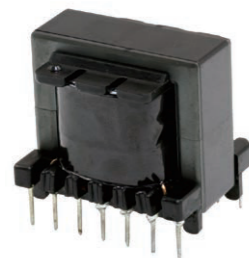

Model	A	B	C	F	G	N	Fig	Reference output power	Ae(mm ²)of core
EE0804	8.7	8.0	8.0	6.0	2.5	3-3	1	-	8.1
EE1005	10.5	11.0	10.5	8.0	2.6	4-4	1	-	10.3
EI1205A	13.0	9.5	12.5	7.5	2.5	5-5	1	-	15.0
EE1306	13.5	13.0	13.0	8.5	2.5	5-5	1	-	17.3
EE1605A	17.0	16.5	13.0	10.5	3.25	5-5	1	4W	19.8
EE1607	16.5	15.5	14.0	11.0	3.3	5-5	1	-	24.0
EE1905A	19.5	17.5	15.0	10.0	5.0	4-4	1	7W	22.8
EE1905C	22.0	18.5	16.0	12.5	4.0	5-5	2	7W	22.8
EE2206	22.5	20.5	17.0	12.5	5.0	4-4	1	10W	41.0
EE2206A	22.5	19.0	17.0	12.0	4.0	5-5	1	10W	41.0
EE2206M	22.5	19.0	18.0	14.0	4.0	5-5	3	10W	41.0
EE2206L	22.5	30.0	17.0	12.5	5.0	4-4	1	30W	35.8
EE2507	26.0	20.5	17.5	12.5	5.0	4-4	1	20W	42.9
EE2507A	26.5	20.0	19.0	15.6	4.5	5-6	4	20W	42.9
EE2507T	26.0	21.0	18.0	12.5	5.0	5-5	1	20W	42.9
EE3313D	34.0	31.0	28.0	22.5	5.0	7-7	1	120W	117
EE3313T	44.0	34.0	28.0	22.5	5.0	9-9	1	120W	117
EE3510D	38.5	45.0	27.5	22.5	5.0	8-8	1	160W	100
EE4012B	43.0	41.0	33.0	25.0	5.0	9-9	1	160W	134
EE4016	43.0	41.0	34.5	25.0	5.0	9-9	1	180W	182
EE4215	55.0	50.0	35.0	25.0	5.0	11-11	1	300W	180
EE4220	55.0	50.0	40.0	28.0	5.0	11-11	1	400W	236
EI5015	51.0	44.0	36.0	27.5	7.5	6-6	1	300W	230
EI6016	60.5	48.0	45.0	35.0	7.5	6-6	1	400W	247

* Outline output power calculate at 100kHz Circuit method :flyback converter

Specifications are subject to change for improvement without notice.

SWITCHING POWER TRANSFORMERS

ER-AS

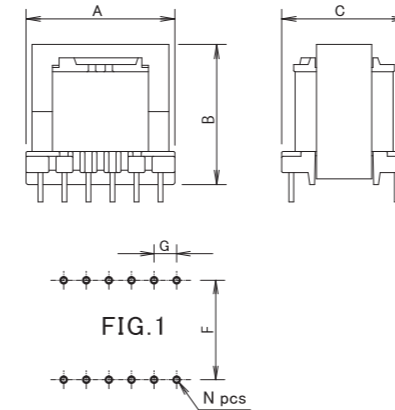

Model	A	B	C	F	G	N	Fig	Reference output power	Ae(mm ²)of core
ER2507T	26.0	21.0	19.6	12.5	5.0	4-4	1	20W	44.4
ER2507	26.0	20.5	19.5	15.0	3.75	7-7	1	20W	44.4
ER2810SB	30.0	23.5	25.0	17.5	5.0	6-6	1	35W	76.4
ER2810SC	30.0	23.5	25.0	20.0	5.0	6-6	1	35W	76.4
ER2810SD	30.0	21.5	22.5	17.5	5.0/3.5	6-8	1	35W	76.4
ER2810SE	29.0	22.0	22.5	17.5	5.0	5-5	1	35W	76.4
ER2810T2	29.0	30.0	23.0	17.5	5.0	5-5	1	60W	82.1
ER2810A	31.0	32.0	25.0	20.0	4.0	8-8	1	60W	82.1
ER2810N	31.5	31.5	22.5	17.5	5.0	6-6	1	60W	82.1
ER2810TL	29.0	35.0	23.0	17.5	5.0	5-5	1	80W	81.4
ER2810LJ	31.5	37.0	22.5	17.5	5.0	6-6	1	80W	81.4
ER2810LHJS	38.5	36.5	26.5	20.0	4.0	9-9	1	80W	81.4
ER3510T	36.0	44.0	28.0	22.5	5.0	6-6	1	160W	107
ER3511A	38.5	48.0	27.5	22.5	5.0	8-8	1	160W	107
ER3913T	39.0	48.0	29.0	25.0	5.0	7-7	1	200W	129
ER4014	40.5	48.0	33.0	25.0	5.0	8-8	1	240W	149
ER4014T	40.5	46.0	30.0	25.0	5.0	6-6	1	240W	149
ER4215T	43.0	46.0	29.0	25.0	5.0	7-7	1	260W	194
ER4220T2	44.5	46.0	37.0	30.0	7.5	6-6	1	280W	240
ER4220T	43.5	46.0	35.0	30.0	5.0	7-7	1	280W	240
ER4917	49.5	56.5	37.0	28.0	5.0	9-9	1	400W	243

* Outline output power calculate at 100kHz Circuit method :flyback converter

EE.ER-AF

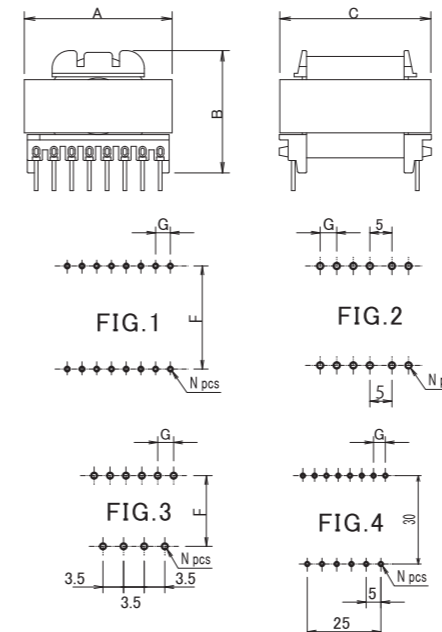
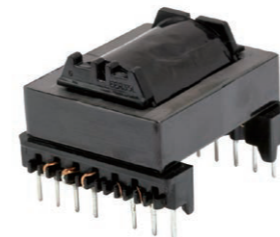

Model	A	B	C	F	G	N	Fig	Reference output power	Ae(mm ²)of core
EE1605T	16.5	13.5	15.0	11.0	3.0	4-4	1	4W	19.8
EE1605F	16.5	15.5	26.0	22.0	2.5	5-5	1	4W	19.4
EE1605AF	16.5	12.5	15.5	12.0	3.5/2.7	4-6	3	4W	19.8
EE1905F	19.5	16.0	16.5	12.0	3.25	5-5	1	7W	22.8
EE2206F	24.0	20.0	31.0	22.5	3.75	6-6	2	20W	35.8
EE2507F	26.0	18.0	22.0	16.0	5.0	5-5	1	20W	42.9
ER2810Z	29.0	24.5	31.0	25.0	5.0	6-6	1	60W	82.1
ER2810AF	29.0	26.0	38.0	30.0	5.0	6-6	1	80W	81.4
ER2810SWAF	31.5	25.0	37.5	30.0	5.0/4.0	6-8	4	80W	81.4
EE3107	32.0	19.0	21.0	15.0	5.0	6-6	1	60W	88.1
EE3510DF	40.0	29.0	44.0	35.0	5.0	8-8	1	160W	100
ER3511F	40.0	29.0	44.0	35.0	5.0	8-8	1	160W	107
ER4014AF	40.5	33.0	46.0	35.0	5.0	8-8	1	240W	149
ER4216TF	42.5	35.0	45.0	35.0	5.0	8-8	1	260W	194
ER4917TF	50.5	42.0	60.0	50.8	6.35	8-8	1	400W	243

* Outline output power calculate at 100kHz Circuit method :flyback converter

Specifications are subject to change for improvement without notice.

SWITCHING POWER TRANSFORMERS

EP-AF



Model	A	B	C	F	G	N	Fig	Reference output power	Ae(mm ²)of core
EP1305T	13.7	8.0	13.7	10.5	2.5	5-5	1	-	11.9
EP1505HJS	15.5	8.5	16.2	13.7	3.8	4-4	1	-	13.5
EP1706T	18.0	12.5	17.5	15.0	2.5	4-6	3	3W	20.1
EP1906T	19.5	12.0	20.0	16.25	2.5	5-6	4	6W	23.0
EP2508T	25.5	16.5	25.5	20.0	3.75	5-6	2	20W	43.0
EP2708T	27.5	15.5	32.5	27.5	3.75	5-6	2	30W	48.3
EP3008T	30.5	16.0	35.5	30.0	5.0	6-6	1	40W	56.4

* Outline output power calculate at 100kHz Circuit method :flyback converter

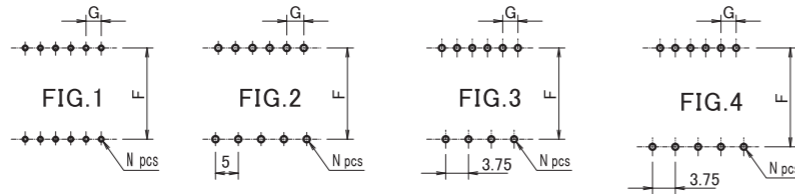
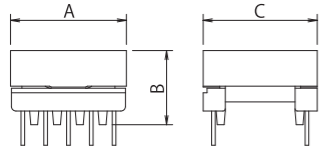

EH-AF



Model	A	B	C	F	G	N	Fig	Ae(mm ²)of core
EH1605	16.5	12.5	15.5	12.5	2.5	6-6	1	19.8
EH1906	19.5	11.5	22.0	16.5	2.5	6-6	1	23.0
EH2207	22.5	19.5	18.5	12.0	4.0	5-4	2	41.0
EH2508T	25.5	14.0	25.5	20.0	3.75	6-5	3	43.0

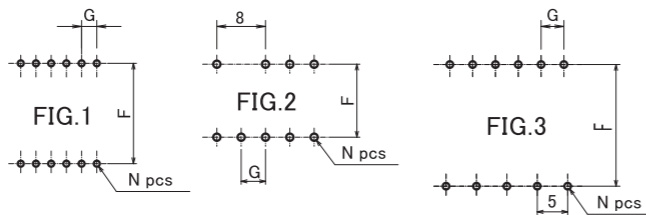
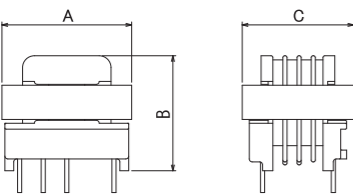

SMD



Packing spec : taping ,tray or carton box

Model	A	B	C	D	E	F	G	H	N	Fig	Ae(mm ²)of core
ER0905	9.5	6.0	11.6	0.3	6.0	11.0	2.0	0.6	4-4	1	8.6
ER1104	11.5	5.5	12.4	0.35	8.0	11.8	2.0	0.52	5-5	1	11.4
ER1105T	11.5	6.5	12.2	0.35	8.0	11.8	2.0	0.52	5-5	1	11.7
ER1406	15.0	7.5	16.0	0.4	10.0	15.3	2.5	0.7	5-5	1	17.6
EP1004AS	11.0	5.5	11.5	0.35	6.0	11.0	2.0	0.52	4-4	1	9.4
EM1203	13.0	6.0	16.7	0.35	6.0	16.2	2.0	0.52	4-4	1	12.3
EM1203A	13.0	6.0	16.7	0.35	8.0	16.2	2.0	0.52	5-5	1	12.3
EP1305AST	14.0	8.5	20.3	0.4	12.0	18.8	3.0	0.6	5-5	1	11.9
EP1706AS	18.0	11.0	23.0	0.5	14.0	21.8	3.5	1.0	4-5	2	20.1
EP1906AS	20.0	11.0	25.0	0.5	17.5	23.8	3.5	1.0	4-6	3	23.0
EP2506	25.5	11.0	28.7	0.4	17.5	27.5	3.5	0.7	5-6	4	33.0

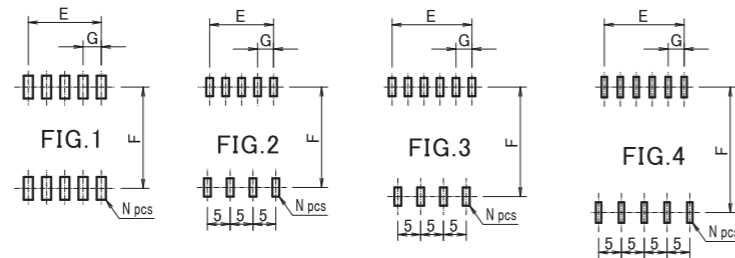
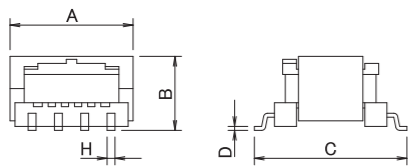

Specifications are subject to change for improvement without notice.

SWITCHING POWER TRANSFORMERS

EI·EE·ER-T.I.W.

- Suitable for low power.
- Able to keep creepage distance approximately 6mm required by IEC standard.
- Possible to attain miniaturization by using special bobbin and triple insulation wire.

海外向け小電力に最適！AC200V系の絶縁トランスは、容量が小さくてもIEC規格により6mm前後の沿面距離が必要。
特殊ボビンと三層絶縁電線で小型化を実現。



Model	A	B	C	F	G	N	Fig	Ae(mm ²)of core
EE1605BF	17.5	15.0	19.5	15.5	3.25	5-5	1	19.8
EE1905D	19.5	19.0	16.0	12.0	3.25	4-5	2	22.8
EE2206B	23.0	23.0	17.0	12.0	4.0	5-5	1	41.0
EI2811C	28.5	21.0	30.5	25.0	4.0/5.0	6-6	1	88.7
ER2810BF	35.0	23.0	43.0	37.5	5.0	6-6	1	81.4

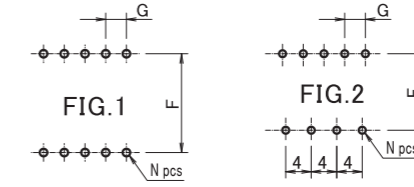
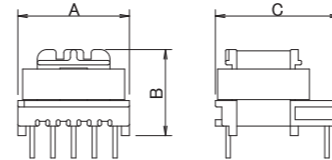

EI·ER·ED-INV

- Available for multiple output.
- Excellent insulation between outputs.
- Suitable for gate drive to control inverter and servo amplifier.
- Possible to design based on IEC/UL61800-5-1.

多出力かつ出力間の絶縁に優れ、インバータやサーボアンプ制御のゲートドライブに最適です。
安全規格IEC/UL61800-5-1に準拠して設計いたします。

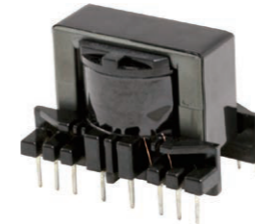

Model	A	B	C	N	Fig	Ae(mm ²)of core
ER2810SM	35.0	24.0	25.0	8-8	1	76.4
ED3312	41.5	31.0	28.5	8-10	2	84.2
EI3513F	43.0	29.0	31.0	13-13	3	129.9
ER3913SWA	48.0	30.5	31.0	18-18	4	136.0

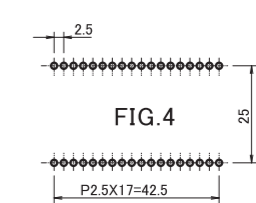
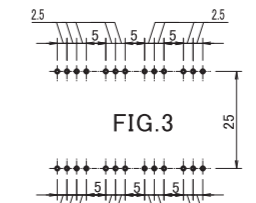
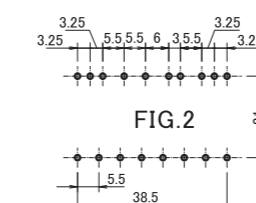
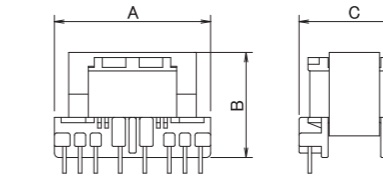
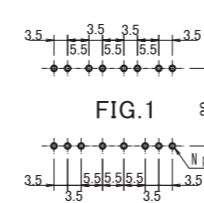

PQ

* Outline output power calculate at 100kHz Circuit method :flyback converter

Model	A	B	C	F	G	H	N	Fig	Reference output power	Ae(mm ²)of core
KPQ2016	23.0	18.5	23.0	20.32	-	-	6-8	2	10W	64.8
KPQ2020L	23.0	24.0	23.0	20.32	-	-	6-8	2	25W	64.3
KPQ2620	27.0	22.5	29.0	25.4	3.81	7.62	6-6	1	35W	125
KPQ2625	27.0	27.5	29.5	25.4	3.81	7.62	6-6	1	60W	124
KPQ3220	32.5	22.0	34.0	30.48	5.08	7.62	6-6	1	60W	156
KPQ3230	32.5	32.0	34.0	30.48	5.08	7.62	6-6	1	180W	155
KPQ3535Z	35.5	40.5	39.0	35.56	5.08	10.16	6-6	1	300W	171
KPQ4040	41.0	45.0	42.0	38.1	5.08	15.24	6-6	1	350W	190
KPQ5050Z	51.0	56.5	51.0	45.72	7.62	12.7	6-6	1	500W	331

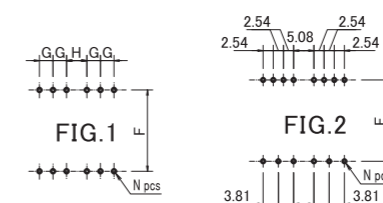
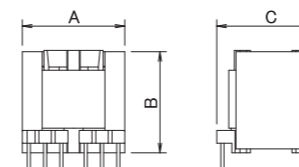

Specifications are subject to change for improvement without notice.

RESONANT TRANSFORMERS

ER-LLC

- Transformer for LLC resonant power supply.
- Incorporate split bobbin.
- Possible to conform safety standard in each country.

分割ボビンを用いたLLC共振電源用トランスです。
各国安全規格に適合いたします。

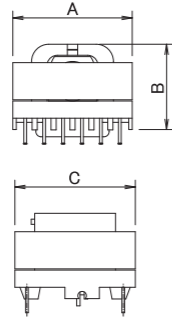

Model	A	B	C	F	G	N	Fig	Ae(mm ²)of core
ER3410BSWA	35.0	25.0	36.0	28.0	5.5	6-6	1	97.0
ER3410BPIN	42.0	25.5	35.5	27.9	5.8	7-7	2	97.0
ER3913BPIN	43.5/53.5	25.0	50.5	36.8	5.8/4.8	7-11	3	134
ER4014BSWA	42.0	30.5	45.0	38.0	5.8	7-7	2	149
ER4916BPIN	50.5/71.5	38.0	53.5	44.6	7.0	7-10	4	221

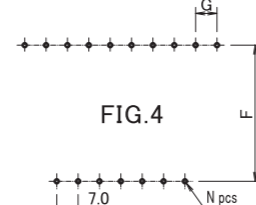
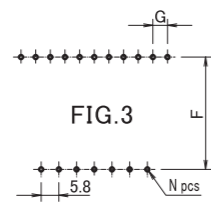
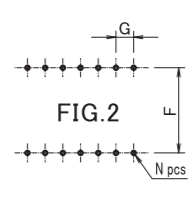
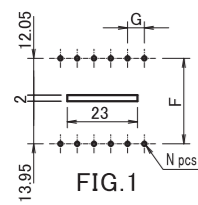

BIG POWER TRANSFORMERS

EE·ER-HP

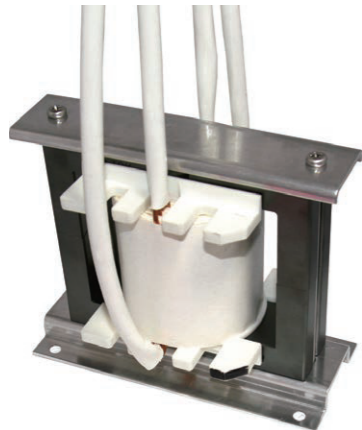

Model	A	B	C	Ae(mm ²)of core
EE8020	105.0	93.0	61.0	406
EE8040	105.0	93.0	81.5	812
ER7016	106.0	86.0	56.0	280
ER9030	115.0	107.0	76.0	626
ER12030	144.5	118.0	76.0	772

